



**INSTALLATION, OPERATION  
&  
MAINTENANCE INSTRUCTIONS**

1455 Kleppe Lane ♦ Sparks, NV 89431-6467 ♦ (775) 359-4712 ♦ Fax (775) 359-7424  
E-mail: [haws@hawsco.com](mailto:haws@hawsco.com) ♦ website: [www.hawsco.com](http://www.hawsco.com)

No. 2080060(15)

**Model 7601.10.2  
Portable Eyewash**

**NOTE TO INSTALLER: Please leave this information with the Maintenance Department.**

**LIMITED WARRANTY**

HAWS warrants that this specific product is guaranteed against defective material or poor workmanship for a period of **one year from date of shipment**. HAWS liability under this warranty shall be discharged by furnishing without charge F.O.B. HAWS Factory any goods, or part thereof, which shall appear to the Company upon inspection to be of defective material or not of first class workmanship, provided that claim is made in writing to Haws within a reasonable period after receipt of the product. Where claims for defects are made, the defective part or parts shall be delivered to the Company, prepaid, for inspection. HAWS will not be liable for the cost of repairs, alterations or replacements, or for any expense connected therewith made by the owner or his agents, except upon written authority from HAWS, Sparks, Nevada. HAWS will not be liable for any damages caused by defective materials or poor workmanship, except for replacements, as provided above. Buyer agrees that Haws has made no other warranties either expressed or implied in addition to those above stated, except that of title with respect to any of the products or equipment sold hereunder and that HAWS shall not be liable for general, special, or consequential damages claimed to arise under the contract of sale.

The emergency equipment manufactured by HAWS is warranted to function if installation and maintenance instructions provided are adhered to. The units also must be used for the purpose for which they were intended. This product is intended to supplement first-aid treatment. Due to widely varying conditions, Haws cannot guarantee that the use of this emergency equipment will prevent serious injury or the aggravation of existing or prior injuries.

**NO OTHER WARRANTIES EXPRESSED OR IMPLIED ARE AUTHORIZED, PROVIDED OR GIVEN BY HAWS.**

**SHOULD YOU EXPERIENCE DIFFICULTY WITH THE INSTALLATION OF THIS MODEL PLEASE CALL:**

**TECHNICAL SUPPORT: 1-800-766-5612**

**FOR CUSTOMER SERVICE: 1-888-640-4297**

**LOCATION OF UNIT:** The Model 7601.10.2 should be placed in close proximity to potential accident areas. It should be clearly identified, free from obstructions and easily accessible.

**NOTE: Personal wash units shall be protected from freezing and shall not be exposed to ambient temperatures exceeding 38°C (100°F).**

## INSTALLATION INSTRUCTIONS

- STEP 1:** Unlock the cover plate on the top of tank. Use potable water to flush and drain the tank at least twice.
- STEP 2:** Fill the tank with potable water up to the top of the water level mark on the tube inside the tank (It may be helpful to locate the mark with a flashlight). Add Sterile Antimicrobial Preservative Model 9082 as directed.
- STEP 3:** Lock the cover plate back in position.
- STEP 4:** Screw the eyewash assembly into the ball valve. Use Loctite 680 on this joint.
- STEP 5:** Charge the tank with clean compressed air to 90 PSI through air valve (tire type).
- STEP 6:** The unit is ready for operation.

## OPERATION INSTRUCTIONS

Self-adjusting flow controls assure a constant even flow of .4 gpm for 15 minutes. Instruct all employees in the use of this Portable Emergency Eyewash. Personnel should be assigned to check eyewash liquid level and pressure before any work starts.

- STEP 1:** Lead the injured to the nearest eyewash station. Seconds can make a big difference in preventing serious eye injury.
- STEP 2:** Push the flag to activate the eyewash.
- STEP 3:** Lower head until eyes enter eyewash stream. Use thumbs and forefingers to hold eyelids open so water can flow on surfaces and in folds surrounding eyeballs.
- STEP 4:** Seek qualified medical attention immediately.

## MAINTENANCE

**NOTE:** Customer must provide an inspection tag and maintain a record of inspection dates and type of maintenance performed (i.e. adding Sterile Antimicrobial Preservative Model 9082, etc.)

- STEP 1:** When water is filled up to the water level mark on the tube inside tank, the unit weighs approximately 92 lbs. Use good judgment to check the water level. See STEP 4 for additional information regarding activated units.
- STEP 2:** Self contained eyewash equipment shall be visually checked to determine if flushing fluid needs to be changed or supplemented. See STEP 4 for additional information regarding activated units.

**STEP 3:** Take proper precautions to help prevent the growth of bacteria in eyewash tank. We recommend either of the following procedures:

- A. Procedure 1: Use suitable Sterile Antimicrobial Preservative Model 9082 to help prevent the growth of bacteria in eyewash tank. Eyewash tank should be drained, flushed and refilled with potable water and Sterile Antimicrobial Preservative Model 9082 as directed by the preservative's manufacturer.
- B. Procedure 2: Drain, flush and refill tank with potable water at least once every week. Thoroughly cleanse tank at least once every month.

**NOTE:** Acanthamoeba survive mild chlorination and are commonly found in tap water. Sterile Antimicrobial Preservative Model 9082 will prevent the growth of Acanthamoeba. Hot water, 158°F (70°C) or hotter will destroy Acanthamoeba but must be allowed to cool prior to use in eyewash units.

**IMPORTANT:**

Before refilling the tank with water, bleed pressure from the tank by opening relief valve on the oval cover.

**STEP 4:** After activating units for whatever reason, ensure the following steps are implemented:

- A. Refill tank with potable water to the watermark line.
- B. Recharge with clean air to 90 psi, if applicable.
- C. If water is discharged for any reason – follow Procedure 1 or Procedure 2 of Step 3 above to ensure that water quality is maintained.

<b>TROUBLESHOOTING</b>	
<b>PROBLEM</b>	<b>REPAIR CHECKLIST</b>
1. No flow.	1. a. Tank empty. Refill tank. b. Obstruction in line of fitting. Clean obstruction.
2. Poor flow.	2. a. Tighten head assembly. b. Check for obstructions. If necessary, remove eyewash head(s) and clean flow control.
3. Eyewash flows for less than 15 minutes.	3. a. Fill tank with water up to the top of the water level mark on tube. b. Fill tank with pressurized air to 90 psi.

For more information about Haws products, see our website: [www.hawsco.com](http://www.hawsco.com)

# PARTS BREAKDOWN

ITEM	DESCRIPTION	PART NO.
1	VALVE, AIR	0006522676
2	GAUGE, PRESSURE	0002580702
3	VALVE, RELIEF	0006520715
4	COVER, POP-OFF	9094
5	HEAD, EYEWASH	SP12
6	FLOW CONTROL	0012506950
7	SQUEEZE VALVE	SP248
8	HOSE	SP142
9	VALVE	SP227
10	HEAD EYE/FACE	0002974804
11	STERILE ANTIMICROBIAL PRESERVATIVE	9082

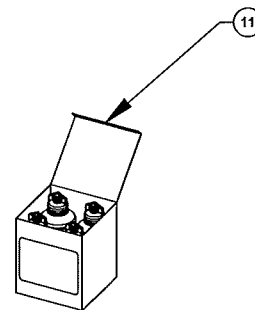
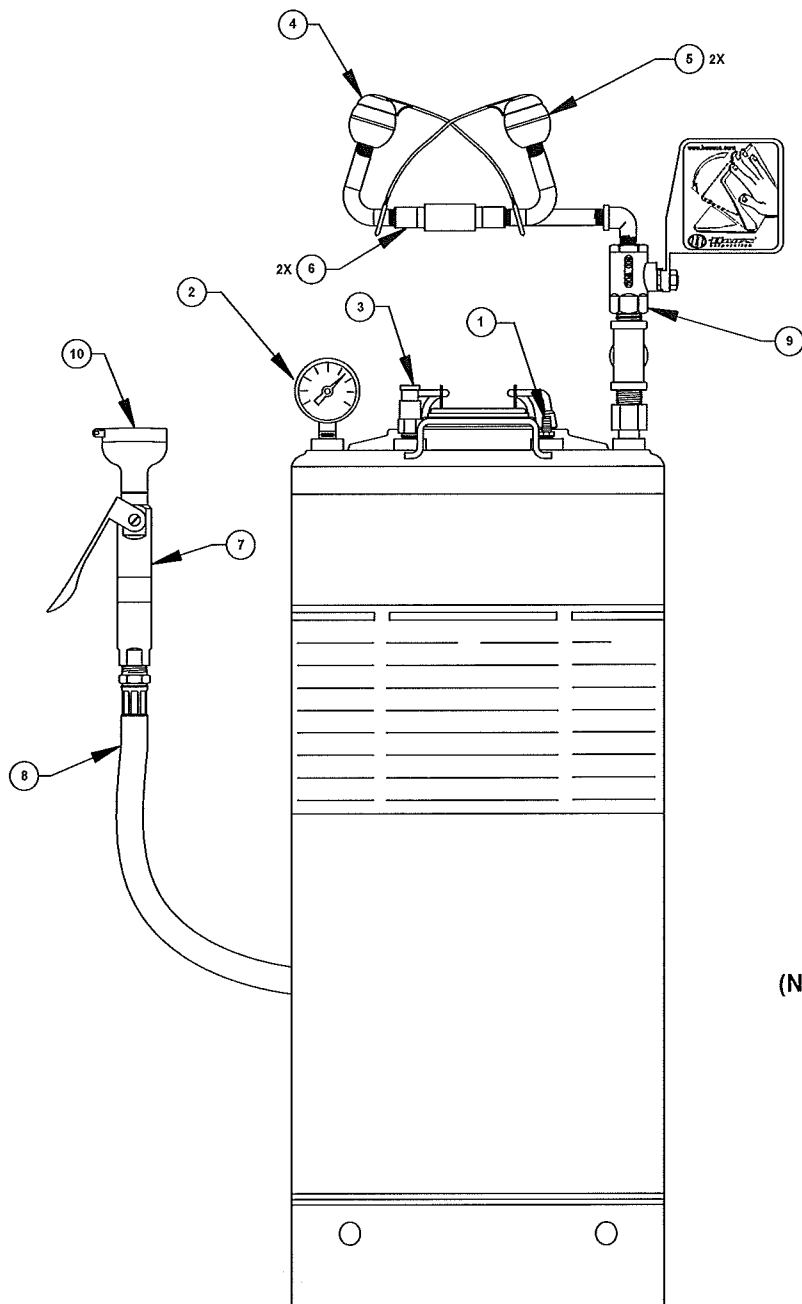

(NOT SUPPLIED, MUST BE ORDERED SEPARATELY)

		1465 KLEPPE LANE SPARKS, NEVADA 89431 (775) 359-4712 FAX (755) 359-7424 E-MAIL: HAWS@HAWSCO.COM WEBSITE: WWW.HAWSCO.COM	
		ECN NO. REVISED PER BY ECN: 4742 JHM	MODEL(S) 7601.10.2
DRAWN EV	DATE 11/25/06	CHECKED JHM	DRAWING NO. 12731C00
APPROVED [Signature]	DATE 1/13/13	SCALE: 1:3   DRAWING TYPE: PARTS BREAKDOWN	SIZE: A   SHEET 1 OF 1

WHEN ORDERING PARTS PLEASE SPECIFY MODEL NUMBER.

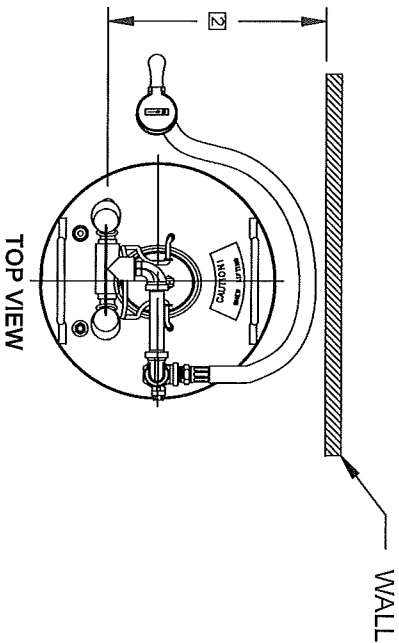

- NOTES:**
1. TO COMPLY WITH ANSI Z358.1-2009 FOR EMERGENCY EYEWASH:  
UNIT SHALL BE INSTALLED IN ACCORDANCE WITH MANUFACTURER'S INSTRUCTIONS AND ACCEPTABLE PLUMBING PRACTICES.

EYEWASH SHALL BE POSITIONED WITH NOZZLES NOT LESS THAN 83.8 CM (33 IN.) AND NO GREATER THAN 114.3 CM (45 IN.) FROM SURFACE ON WHICH USER STANDS AND 15.3 CM (6 IN.) MINIMUM FROM WALL OR NEAREST OBSTRUCTION.

2. EYEWASH HEAD ASSEMBLY MUST BE PARALLEL TO WALL OR OBSTRUCTION TO MEET CRITERIA STATED IN ACCORDANCE TO NOTE 1.

\*3. DIMENSIONS MAY VARY ±1/2" [12.7mm].

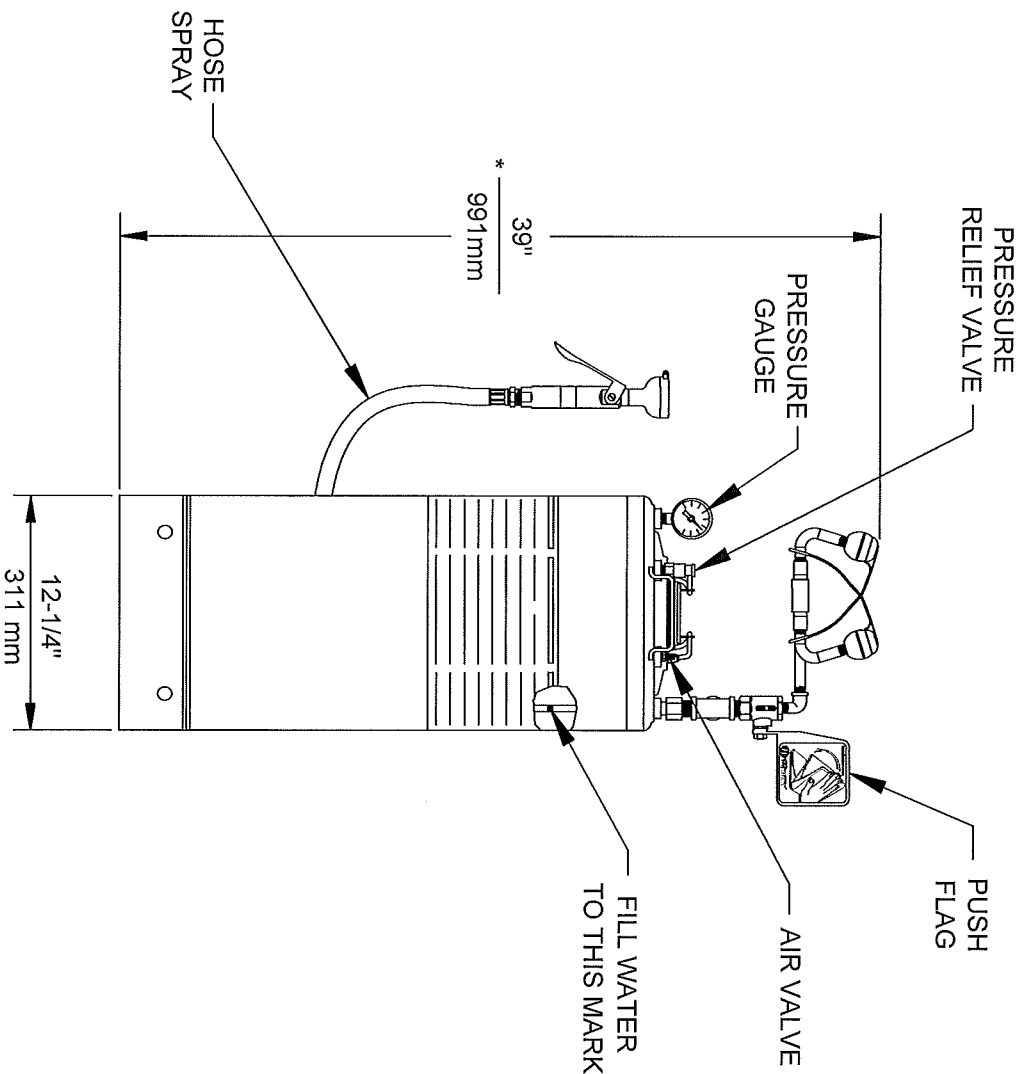

1455 KLEPPE LANE  
SPARKS, NEVADA 89431  
(775) 359-4712 FAX (775) 359-7424  
E-MAIL: HAWS@HAWS.CO.COM  
WEBSITE: WWW.HAWS.CO.COM

EQM NO.	REVISED PER BY:	MODEL(S)	PART NUMBER
7601, 10, 2	EQM-4712	7601, 10, 2	0002080060.D
DRAWN BY:	DATE:	10 GAL EYEWASH	DRAWING NO. REV
APPROVED BY:	DATE:	SCALE: 1:8	12730A00 15
		DRAWING TYPE:	SIZE: A
		INSTALLATION:	SHEET: 1 OF 1